

PRODUCT INFORMATION

- Aluminium Extrusion
- Weight: 675 grams per meter
- Dimensions: 66 mm x 25 mm
- Supplied with one dimmable led strip.
- LED colour temperature: warm white 3000
- Power: 15 watt/m
- Colours available: White, Anthracite
- Warranty: 10 years (Excluding LED)

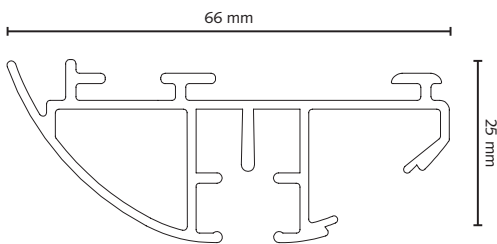

Easywave

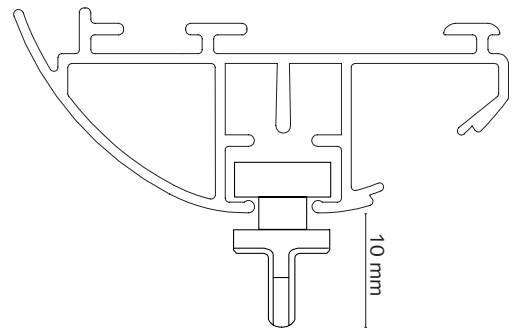

MOUNTING BRACKETS

Klick Ceiling Bracket

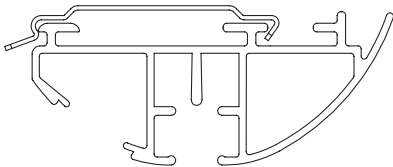

Ceiling Swivel Bracket

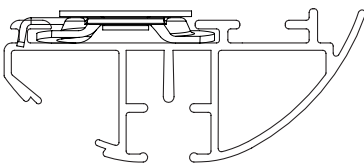

Standard

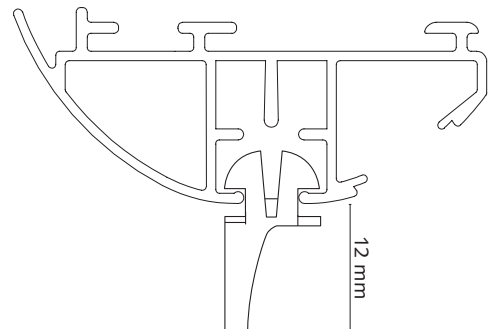

ACCESSORIES

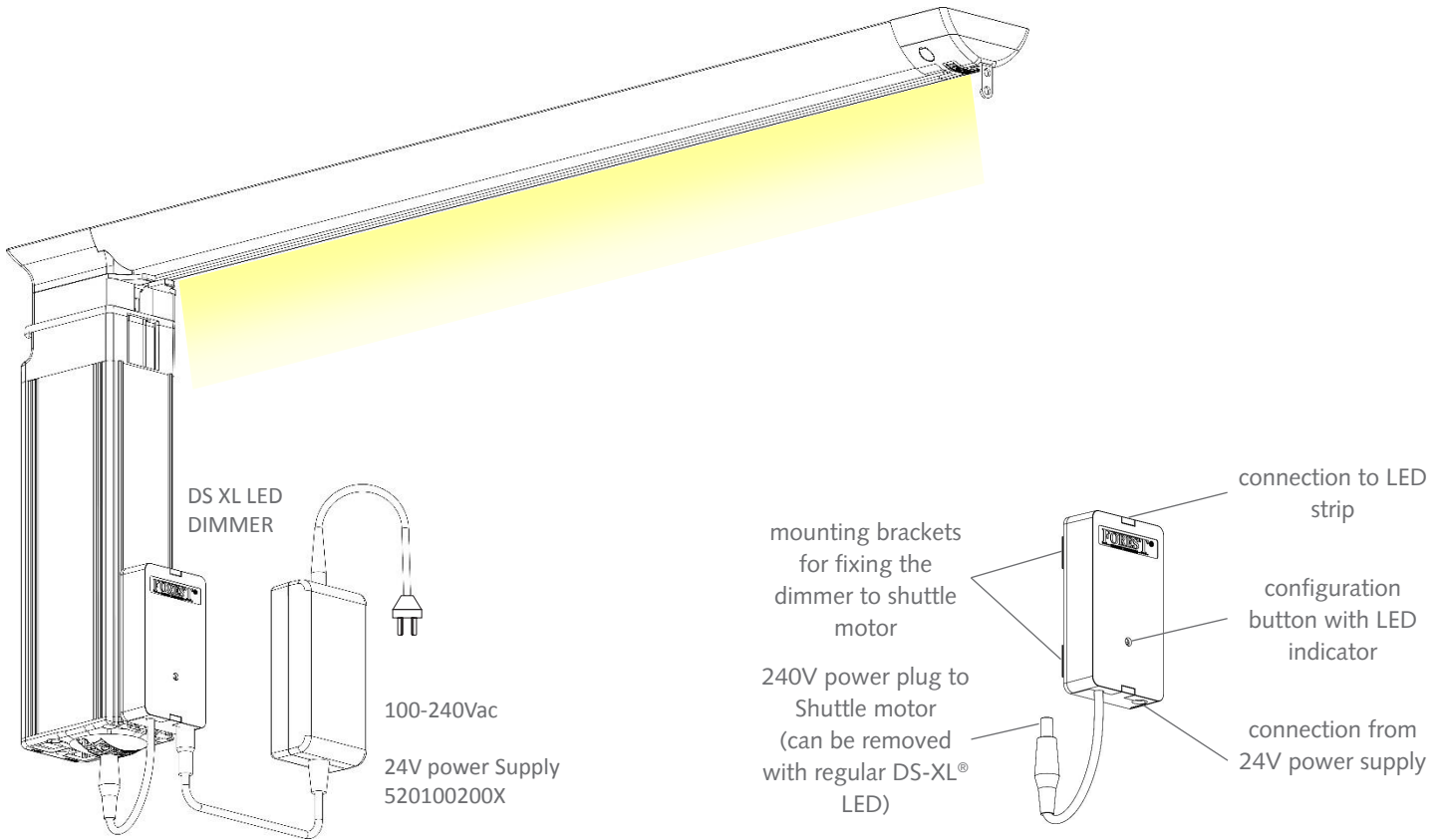

DS-XL TRACK CONNECTOR STRAIGHT

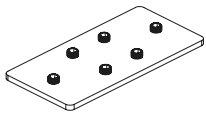

DS-XL TRACK CONNECTOR 90 DEGREES

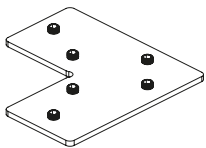

DIAMOND SENSE REMOTE CONTROL



FOREST SHUTTLE® SERIES

The Forest Shuttle® is the silent force behind the opening and closing of draperies all over the world. The Forest Shuttle® is offered in 2 versions for the DS XL LED motorised range. Choose which Forest Shuttle motor best suits your application integration needs:

SHUTTLE® S

24 Volt

Plug & Play motor with external adaptor. Powerful curtain track motor with max curtain weight: 40 kg. Compatible with: FMS®, FMS® Plus recess, DS-XL LED® & MRS®. Suitable for curved tracks. Works with WiFi dongle.









SHUTTLE® M









24 Volt

Plug & Play motor with external adaptor. Ultra powerful curtain track motor with max curtain weight: 70 kg. Compatible with: FMS®, FMS® Plus recess, DS-XL LED® & MRS®. Suitable for curved tracks. Works with WiFi dongle.



UNIQUE FEATURES:

-  Ultra silent motor
-  Automatic declutch & manual operation available
-  Touch Control: a gentle pull on the curtain activates the motor
-  Slow start and slow stop for smooth running curtains
-  Plug & Play motor
-  Stack-back position programmable to every desired setting

-  Designed to create perfectly closed curtains
-  Forest Connect App (for iOS & Android)
-  Forest Diamond Sense & Somfy remote control options
-  Can be controlled with a smartphone or tablet via WiFi
-  Forest Wireless wall switch
-  Voice control
-  Building Automation
-  Variable speed
-  10 year warranty on Shuttle S, M, L & iOn (2 year warranty on battery pack)

	Shuttle S/M	Forest Connect app	Google Home	Apple Homekit	Amazon Alexa	Google Assistant	Apple Siri	Voice control
Forest Wireless Connector One way transmitter to control curtains by third party apps or by Domotics. (433Mhz)	●	● ¹	● ¹	● ²	● ¹	● ¹	● ¹	● ¹
Forest Wi-Fi Dongle in combination with Forest Connect app	●	●	●	●	●	●	●	
Smartwares Controller in combination with HomeWizard lite app (433 Mhz)	●				●			
Homey in combination with Homey app	●		●	●	●	●	●	
FIBARO System in combination with FIBARO Home Center app			●	●	●	●	●	
Samsung SmartThings Hub in combination with Samsung SmartThings app			●	●	●	●	●	
230 Volt hard-wired building management system	● ⁴							

1) In combination with Forest smart plug
2) In combination with Apple Homekit smart plug
3) Only with FIBARO Roller Shutter 3 / Walli Roller Shutter
4) In combination with an AC Control Set

