

PRODUCT INFORMATION

- Aluminium Extrusion
- Weight: 303 grams per meter
- Dimensions: 20 mm x 20 mm
- Bendable; using a 20cm radius
- Colour available: White, Black
- Touch Control Technology activate the motor by gently pulling the curtain by hand.
- The Forest Shuttle® can be connected to any home or building automation system by relay control
- Track finish: chromated powder coating with a factory applied patented dry lubricant
- Warranty: 10 years

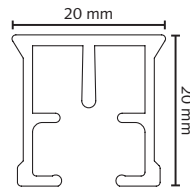

BENDING / CURVING

The track can be bent, reverse bent and continuously curved.

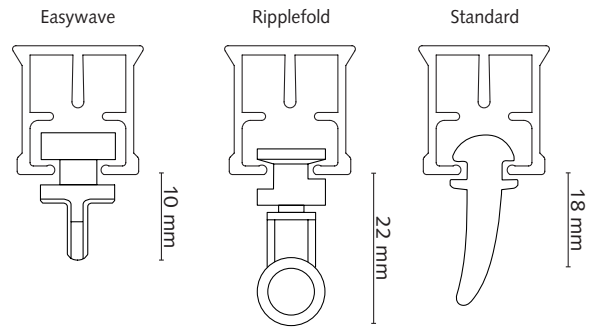
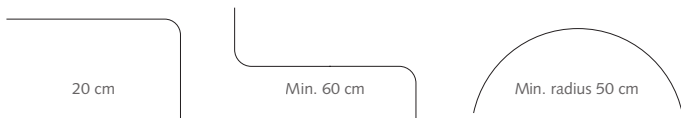

APPLICATIONS

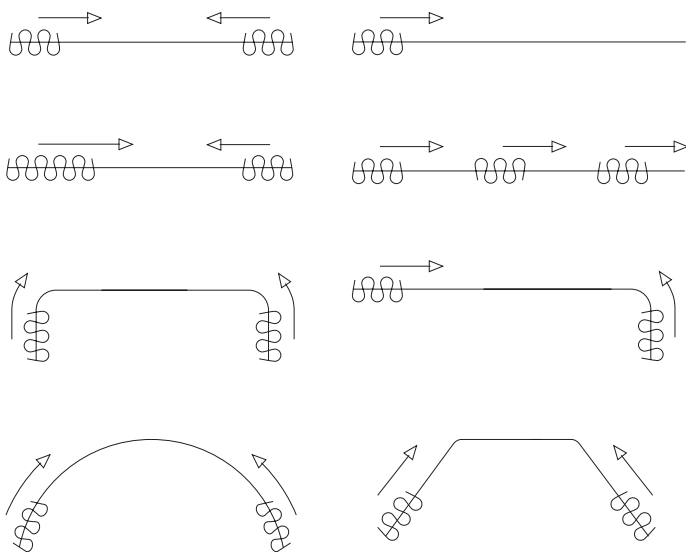

MOUNTING BRACKETS

Smart Klick Ceiling Bracket

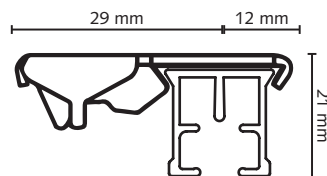

Ceiling Bracket

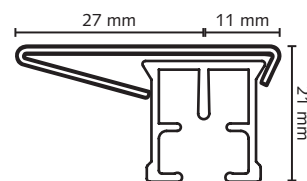

ACCESSORIES

Smart Click Ceiling Bracket

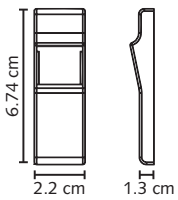
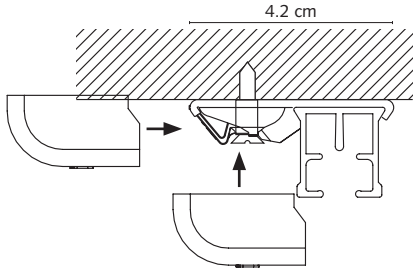

Smart Klick Cover Cap for
 Aluminium Wall bracket

**ADJUSTABLE WALL
 BRACKETS**

Single Adjustable Wall Bracket

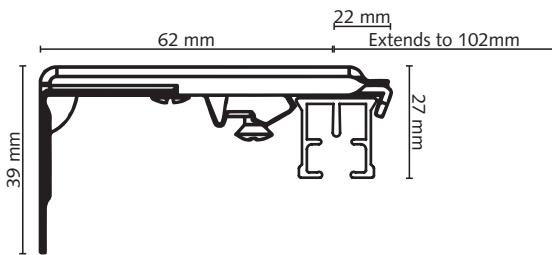

Double Adjustable Wall Bracket

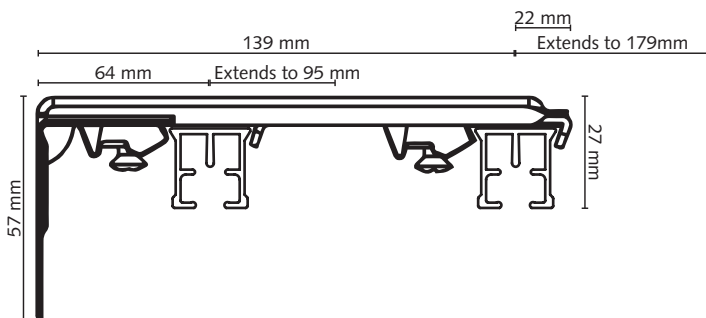

**ALUMINIUM WALL
 BRACKETS**

Aluminium Wall Bracket 7.5 cm

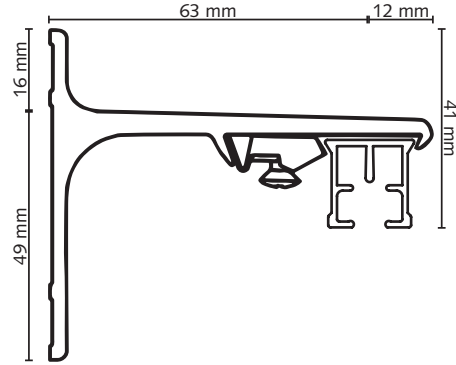

Aluminium Wall Bracket 10 cm

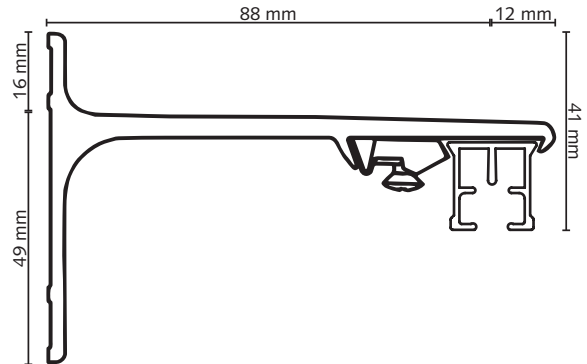

Aluminium Wall Bracket 15 cm Double

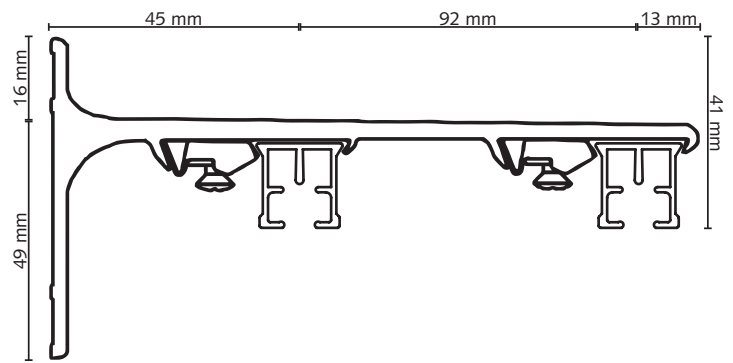

Aluminium Wall Bracket 20 cm Double

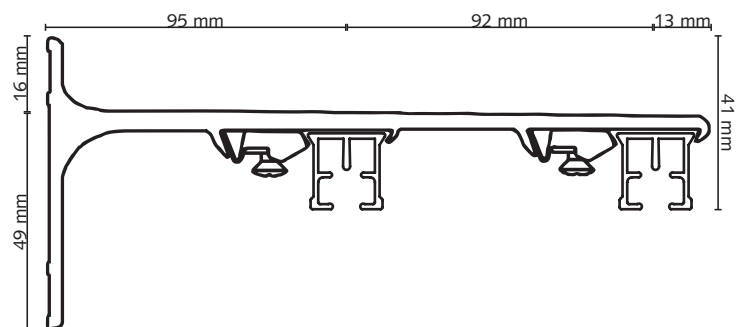

FOREST SHUTTLE® SERIES

The Forest Shuttle® is the silent force behind the opening and closing of draperies all over the world. The Forest Shuttle® is offered in 4 versions. Choose which Forest Shuttle motor best suits your application integration needs:

SHUTTLE® S

24 Volt

Plug & Play motor with external adaptor. Powerful curtain track motor with max curtain weight: 40 kg. Compatible with: FMS®, FMS® Plus recess, DS-XL LED® & MRS®. Suitable for curved tracks. Works with WiFi dongle.



SHUTTLE® M

24 Volt

Plug & Play motor with external adaptor. Ultra powerful curtain track motor with max curtain weight: 70 kg. Compatible with: FMS®, FMS® Plus recess, DS-XL LED® & MRS®. Suitable for curved tracks. Works with WiFi dongle.



SHUTTLE® L

100 - 240 Volt

Plug & Play motor. Powerful curtain track motor with max curtain weight: 40 kg. Compatible with: FMS®, FMS® Plus recess & MRS®. Suitable for curved tracks. Works with WiFi dongle.

















SHUTTLE® iOn

14,8 Volt

Li-ion rechargeable battery. Max curtain weight: 25 kg. Compatible with FMS®, FMS® Plus recess & MRS®. Suitable for curved tracks (max 2 bends). Works with Wireless Connector/Smart Plug. Does not work with WiFi dongle. Normal use: 2-3 recharges per year.



UNIQUE FEATURES:

-  Ultra silent motor
-  Automatic declutch & manual operation available
-  Touch Control: a gentle pull on the curtain activates the motor
-  Slow start and slow stop for smooth running curtains
-  Plug & Play motor
-  Stack-back position programmable to every desired setting
-  Designed to create perfectly closed curtains
-  Forest Connect App (for iOS & Android)
-  Forest Diamond Sense & Somfy remote control options
-  Can be controlled with a smartphone or tablet via WiFi
-  Forest Wireless wall switch
-  Voice control
-  Building Automation
-  Variable speed
-  10 year warranty on Shuttle S, M, L & iOn (2 year warranty on battery pack)

	Shuttle S/M/L	Shuttle iOn	Forest Connect app	Google Home	Apple Homekit	Amazon Alexa	Google Assistant	Apple Siri	Voice control
Forest Wireless Connector One way transmitter to control curtains by third party apps or by Domotics. (433Mhz)	●	●	● ¹	● ¹	● ²	● ¹	● ¹	● ¹	●
Forest Wi-Fi Dongle in combination with Forest Connect app	●		●	●		●	●	●	
Smartwares Controller in combination with HomeWizard lite app (433 Mhz)	●	●				●			
Homey in combination with Homey app	●	●		●	●	●	●	●	
FIBARO System in combination with FIBARO Home Center app				●	●	●	●	●	
Samsung SmartThings Hub in combination with Samsung SmartThings app				●	●	●	●	●	
230 Volt hard-wired building management system	● ⁴								

1) In combination with Forest smart plug
2) In combination with Apple Homekit smart plug
3) Only with FIBARO Roller Shutter 3 / Walli Roller Shutter
4) In combination with an AC Control Set

