

Installation Guide

Motor Operated Rack Arm



GENERAL

Horiso supply packed separately:

1. Components for each section of the system with motor in position
2. Drive shaft assembly is packed in 2 sections
 - the shorter section (X). DO NOT dispose
3. Hardware - brackets, nuts and bolts
4. Slats.

NOTE: Motors and operating components are determined before installation on site and are supplied in position.

This guide will demonstrate 2 standard Rack Arm System installations.

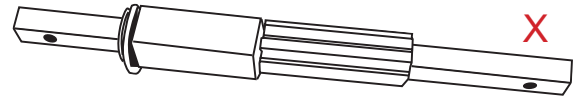
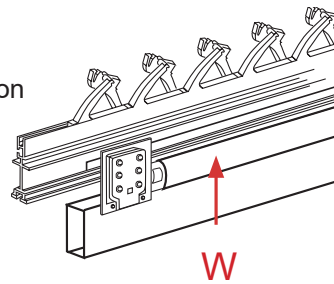

A FACE FIX onto window mullions, building structure or framework – external applications.

B REVEAL on window mullions and building structure - internal and external applications.

NOTE: Non-standard brackets can be sourced by the installer if required to suit installation.

1 - CARRYING / HANDLING

Unpacking Rack Arm Systems

Use 2 men if required - depending on size and weight.

Warning: Be careful using scissors or knife to unwrap rack arms, as you may seriously damage components.

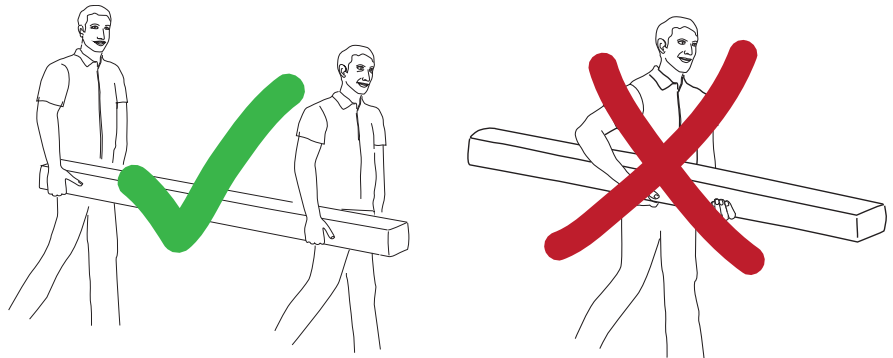

FACE FIX INSTALLATIONS

2A - FIX Z BRACKETS

Space out standard Z brackets every approximately 1500 mm* onto window mullion, building structure or framework.

NOTE: Ensure brackets are not installed in drive shaft location.

*Check particular system requirements

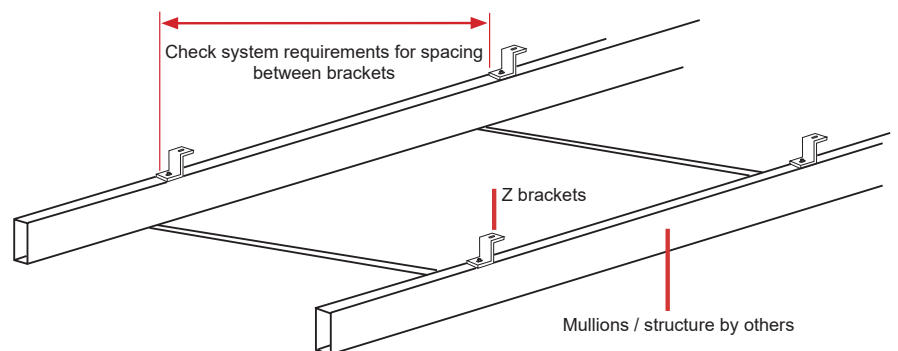

3A - FIX RACK ARM EXTRUSIONS

Fix rack arm onto standard Z brackets using the nuts and bolts provided.

Bolts slide into extrusion from the opposite side of the tilt shaft.

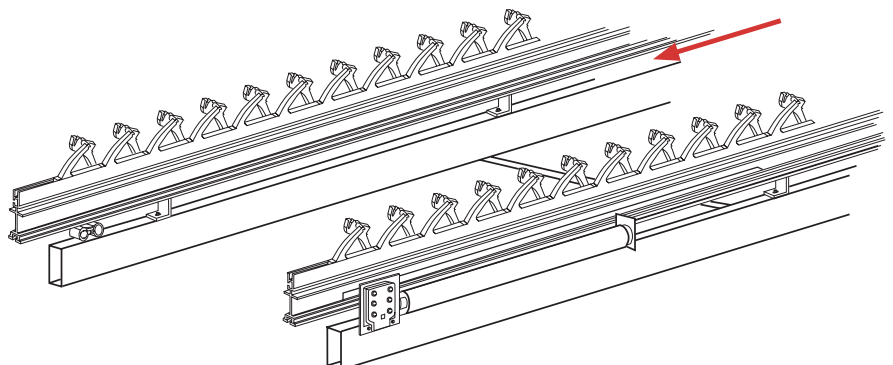
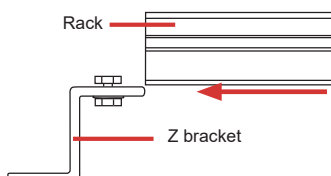

Installation Guide

Motor Operated Rack Arm



4A - INSERT DRIVE SHAFT

1. Insert the shorter drive shaft assembly first into the gear box. Ensure the head of drive shaft positioning is correct (Y) before inserting.

2. Align longer drive shaft (Y) and starting from the opposite end of the gear box feed through tilt shaft and rack arms to join the shorter drive shaft assembly.

NOTE: Ensure all slat clips are in the same position before inserting drive shaft. Drive shaft is supplied as the same length of the slats. Cut drive shaft on site to required length.

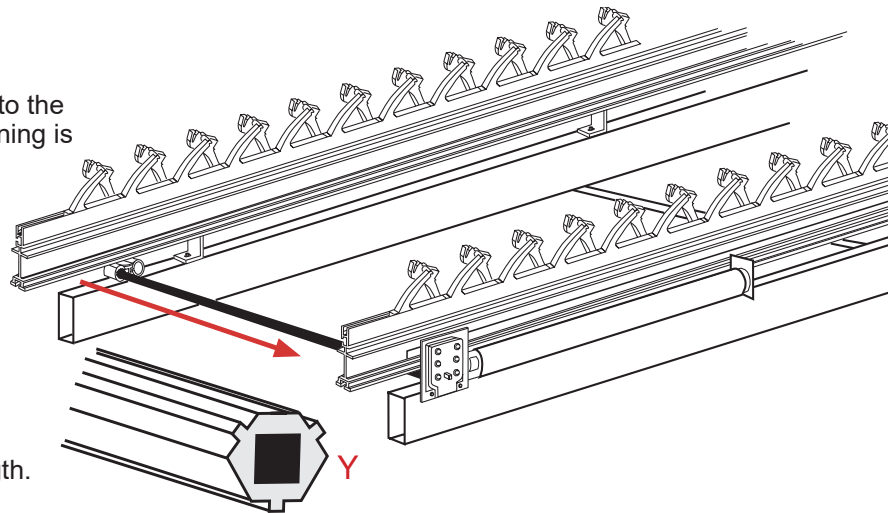

5A - ATTACH SLATS

Slide or clip on from left to right 2 slats onto slat clips and fix with: Supplied screw (75E, 88E). See below.

NOTE: Only attach 2 slats and carefully test motor limits to ensure slats open and close to the right positions without causing damage to the slats. If incorrect, reset limits, go to STEP 7A OR 7B (separate sheet.)

If limits are correct, continue to attach remaining slats onto slat clips until complete.

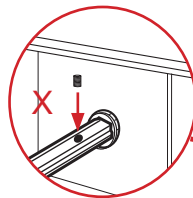
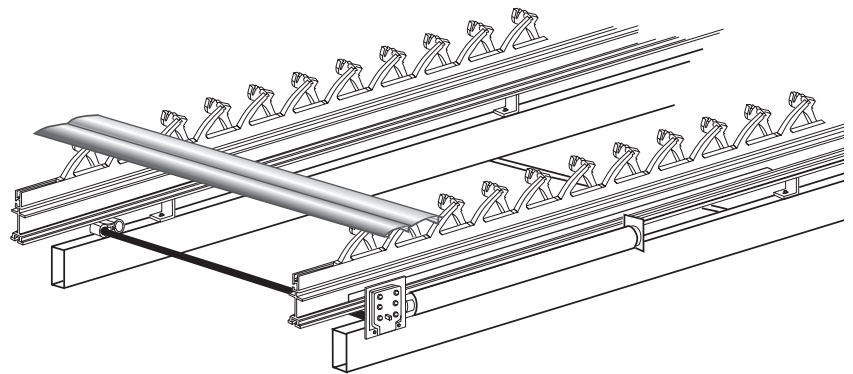

5B - FINALISE ALIGNMENT

Drill hole and fix 5 mm lock screw (X) towards end of drive shaft at motor end to hold the drive shaft's correct alignment position.

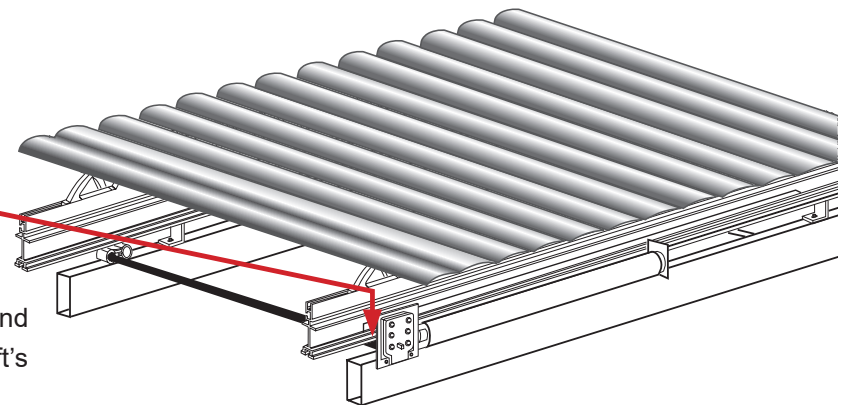

75E, 88E

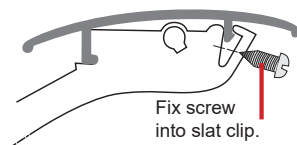

145E, 155E

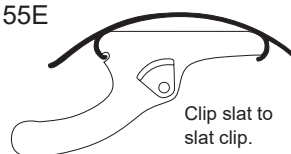

WARNING

Horiso will not be responsible for installations where recommended instructions are not carried out

Disclaimer: These leaflet instructions are a guide ONLY for professional installers.



Installation Guide

Motor Operated Rack Arm



REVEAL FIX INSTALLATIONS 2B - FIX ANGLE BRACKETS

Space out standard angle brackets every approximately 1500 mm* onto window mullion, building structure or framework.

- Alternate fixing (Z) if suitable.

Ensure brackets are plumb to surface.

*Check particular system requirements.

IMPORTANT: Steps 2, 3 & 4 need to be completed before fixing into reveal.

NOTE: Minimum clearance height of 55 mm is required. If a insect screen / handle or other protrusion exists fix brackets to accommodate this clearance.

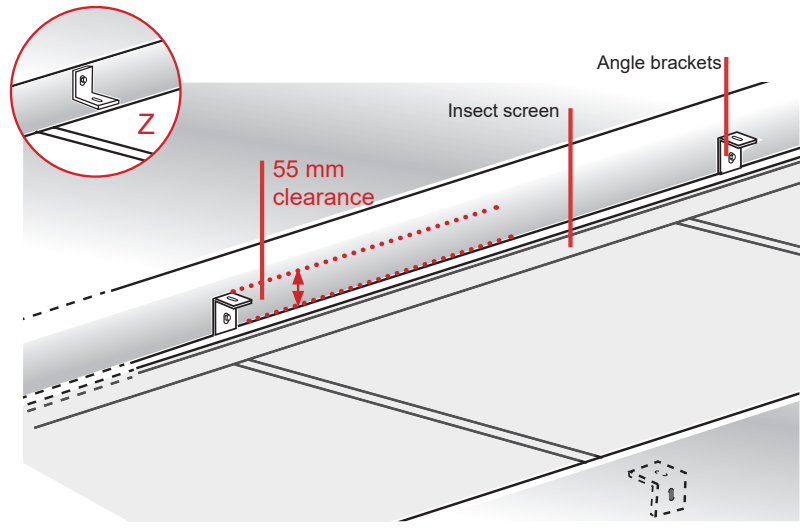

3B - ASSEMBLE RACK ARM EXTRUSIONS

Place all rack arms parallel as per position for reveal fixing.

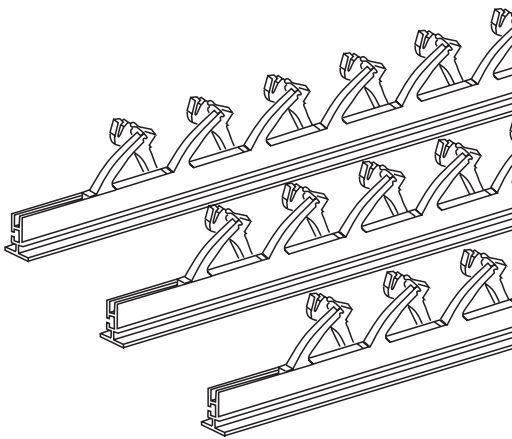

4B - INSERT DRIVE SHAFT

1. Insert the shorter drive shaft assembly first into the gear box. Ensure the head of drive shaft positioning is correct (Y) before inserting.

2. Align longer drive shaft (Y) and starting from the opposite end of the gear box feed through tilt shaft and rack arms to join the shorter drive shaft assembly.

NOTE: Ensure all slat clips are in the same position before inserting drive shaft.

Drive shaft is supplied as the same length of the slats. Cut drive shaft on site to required length.

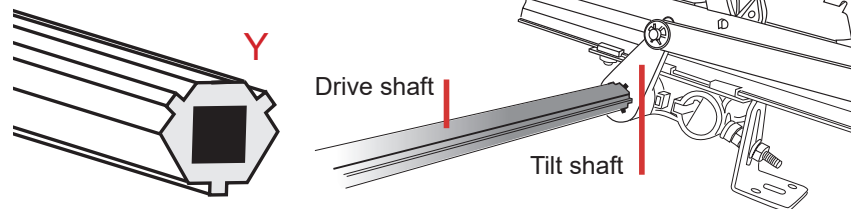

5B - FIX ASSEMBLED COMPONENTS TO ANGLE BRACKETS IN REVEAL

Fit assembled rack arm extrusions with installed drive shaft into reveal and fit to angle brackets.

NOTE: Unsupported reveal installations

Installations on irregular shaped glazing and where rack arms extrusions are unsupported, side edge supports with edge pivots are supplied.

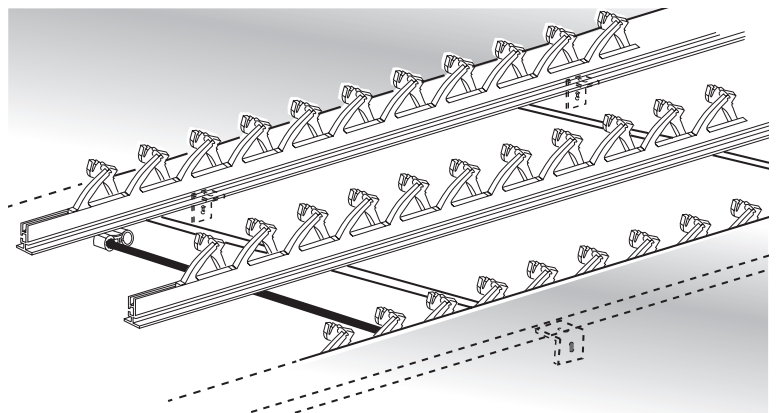

6B - ATTACH SLATS ON RACK ARMS IN REVEAL

Repeat 5A AS PER FACE FIX INSTRUCTIONS.

Disclaimer: These leaflet instructions are a guide ONLY for professional installers.

