

External Unguided Tension System

Freedom to move around curves

TESS400 overcomes challenges without compromising on style. The blind uses relieving rollers which follow the directions of the curve whilst ultra-thin tension cables maintain fabric tension.

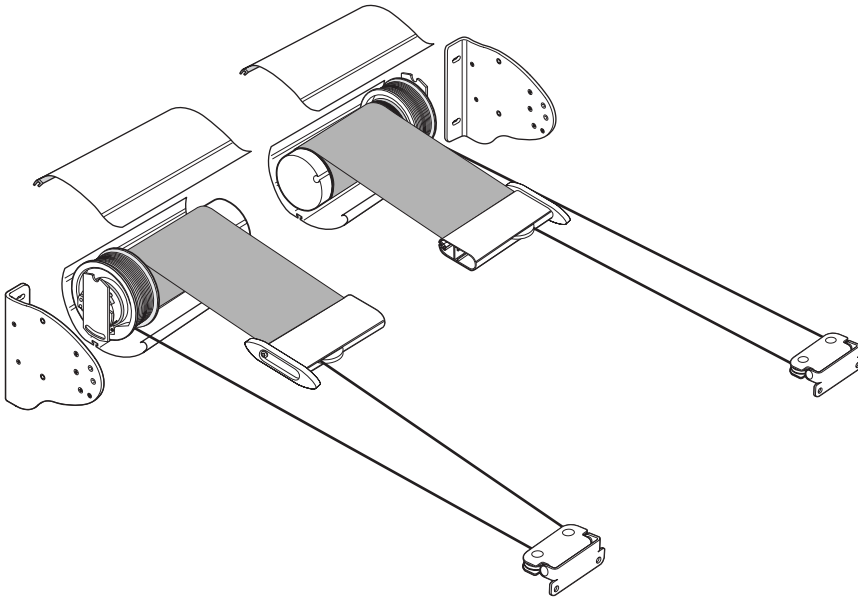

- Protective headbox
- Single barrel system
- Any angle, any direction, any curves
- Reliable and robust
- Various colour finishes and fabric options
- Smooth, quiet travel.

Key Facts

Typical Use

Curved or Vaulted glazing

Shape

Rectangular

Running Direction

Any

Guides

None

Width

870 mm - 4000 mm

Draw

≤6500mm

Fabric Area

≤16 m²

Brackets

Aluminium

Relieving Rollers

Aluminium

Finish

RAL Powder coat

Installation Options

Bottom/Back



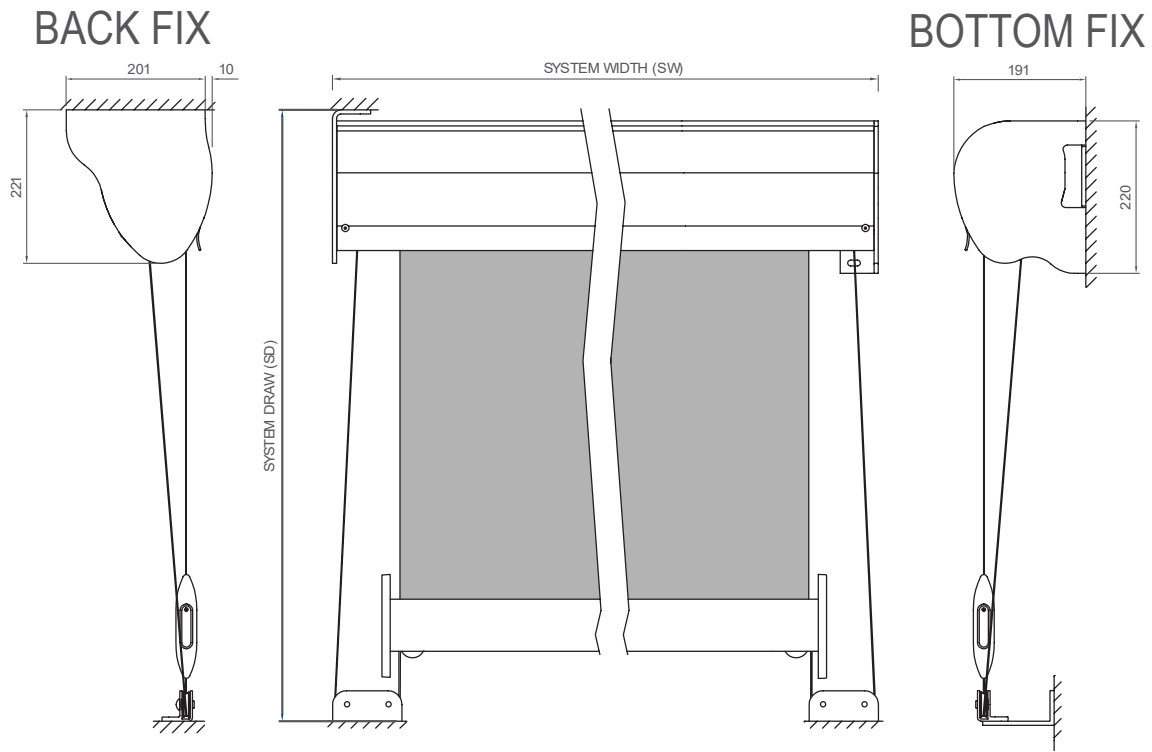

Technical Information

Fabric Tension

>100 N

Weight exc. fabric

~12.5 kg + 10.2 kg/m width

Fixing Load

≤36 kg per bracket

Operating Temp

0 to 55 °C

Motor

15 Nm, 17rpm

Max run time

4 min

Fabric Speed

~5m/ min

Control

Radio/Wired

Electrical

230 V, 50 Hz, 140 W, 0.65A

120 V, 60 Hz, 130 W, 1.1A

