

Compact Unguided Tension System

Stylish solution for smaller spaces

TESS600 has a compact headbox which makes it easier to design into the glaze surrounding for a near invisibility when retracted.

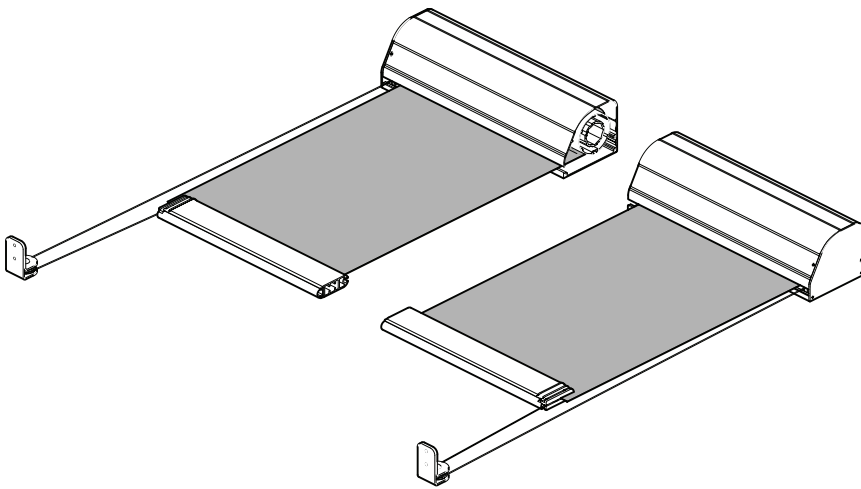

- Compact Single barrel system
- Ultra-quiet motor
- Discrete design
- Smooth, quiet travel.

Key Facts

Typical Use

Flat or sloped glazing

Shape

Rectangular

Running Direction

Any

Guides

None

Width

650 mm - 3000 mm

Draw

≤3000mm

Fabric Area

≤9 m²

Brackets

Aluminium

Relieving Rollers

Aluminium

Finish

RAL Powder Coat

Installation Options

Top/Back



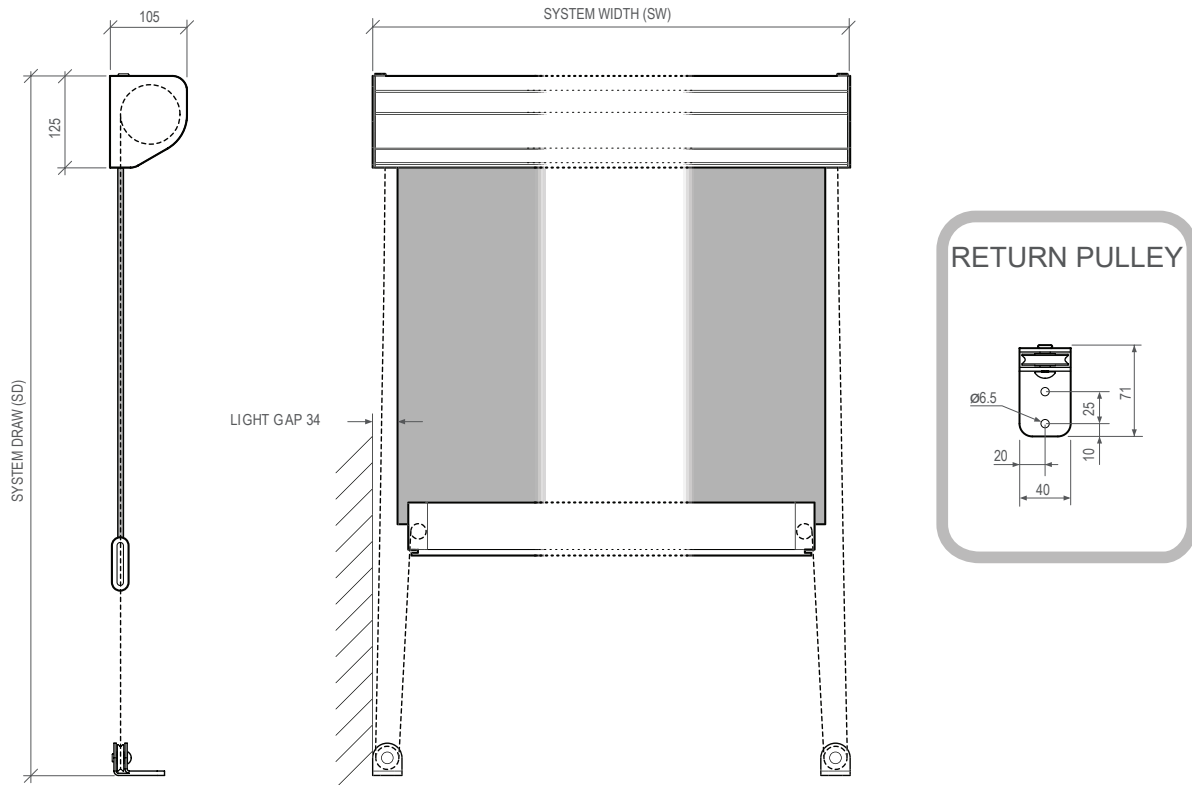

Technical Information

Fabric Tension

>100N

Weight exc. fabric

~8 kg + 4 kg/m width

Fixing load

≤15 kg per bracket

Operating temp.

0 to 55 °C

Motor

9 Nm, 12 rpm

Max run time

4 min

Fabric Speed

~3 m/min

Control

Radio/Wired

Electrical

230 V, 50 Hz, 120 W, 0.55A

120 V, 60 Hz, 130 W, 0.98A

