

Compact Tension System

Stylish solution for smaller spaces

The TESS601 covers corners and right-angled triangles and can even follow curves with the use of relieving rollers. The compact headbox makes it easy to design into glazed surroundings, inside or out, for near invisibility when retracted.

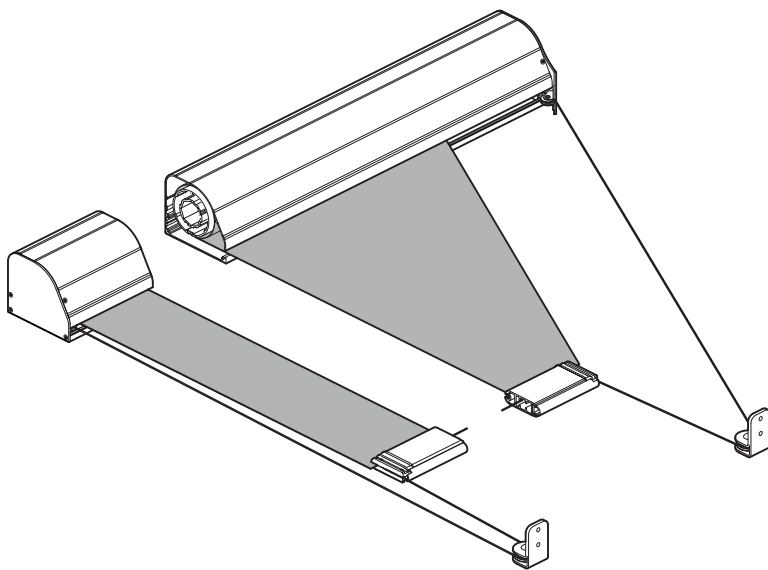

- Compact Single barrel system
- 90° triangles and corners
- Angles and curves
- Ultra-quiet motor
- Reliable and robust
- Wide range of fabrics and colour finish options
- Smooth, quiet travel.

Key Facts

Typical Use

Light structures, retrofit

Shape

Rectangular

Running Direction

Any

Guides

Aluminium Profile

Width

870 mm - 4000 mm

Draw

≤6500mm

Fabric Area

≤16 m²

Brackets

Aluminium

Relieving Rollers

Aluminium

Finish

RAL Powder Coat

Installation Options

Bottom



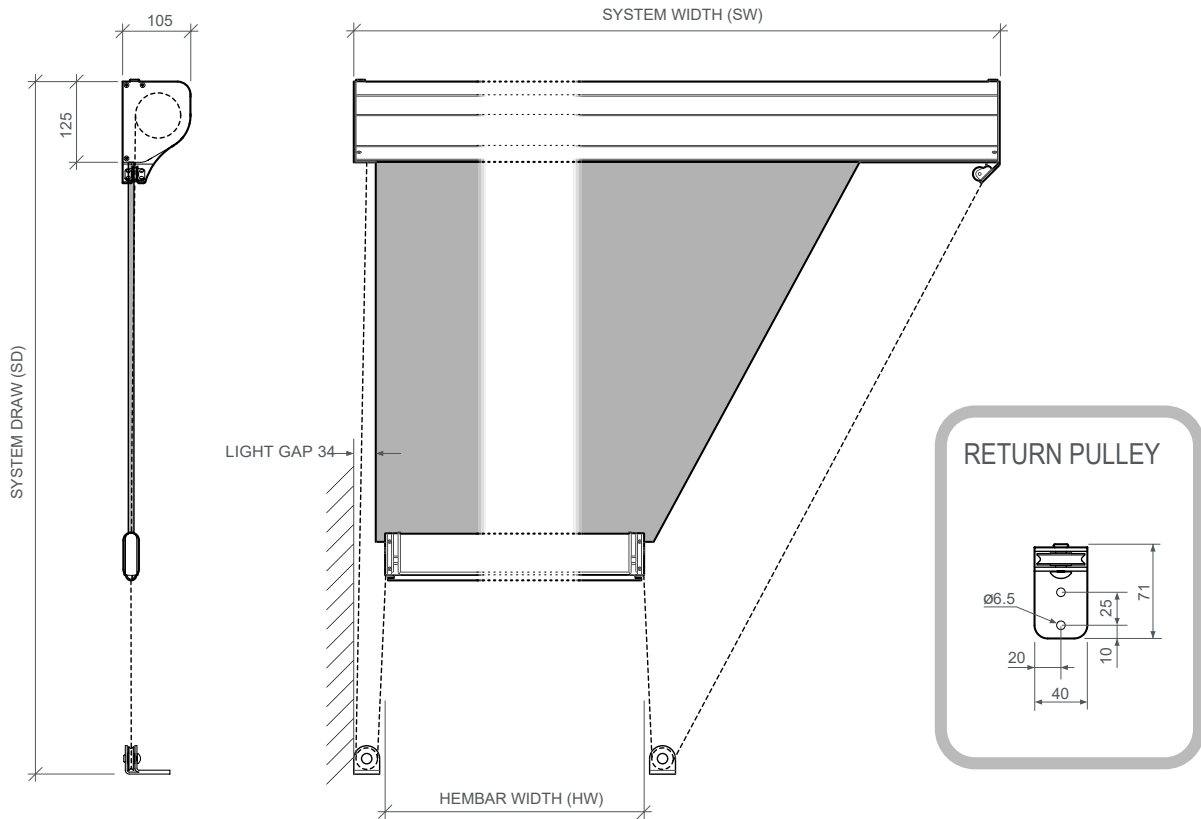

Technical Information

Fabric Tension

>100N

Weight exc. fabric

~10.5 kg + 10.2 kg/m width + 4kg/m draw

Fixing load

≤36 kg per bracket

Operating temp.

0 to 55 °C

Motor

15 Nm, 17rpm

Max run time

4 min

Fabric Speed

~5 m/min

Control

Radio/Wired

Electrical

230 V, 50 Hz, 140 W, 0.65A

120 V, 60 Hz, 130 W, 1.1A

