

SideLock Tension System

Designed to eliminate light gaps

The TESS660 is engineered to deliver total reliability, discrete and is the only tensioned zip screen that will not let you down. Our SideLock mechanism stops the fabric blowing out of its guides. Suitable for internal and external use.

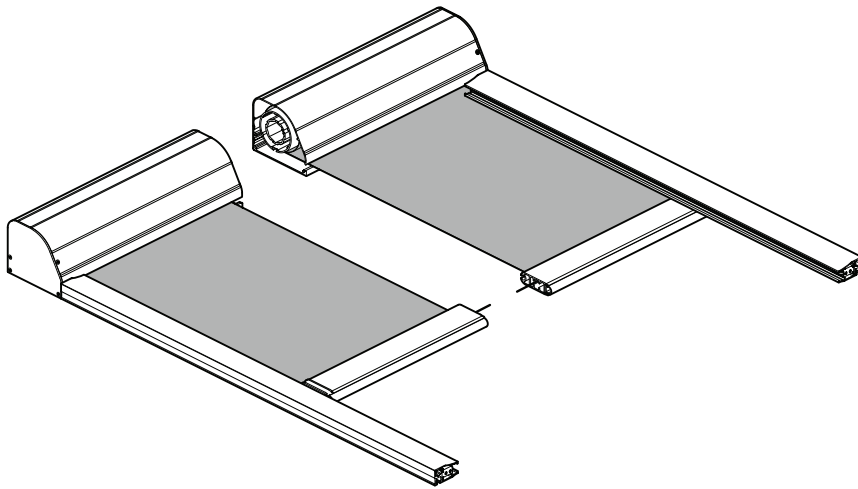

- CE marked wind class 3
- Any angle, any direction
- Blackout capability
- SideLock fabric retention
- Ultra-quiet motor
- Wide range of fabrics and colour finish options
- Smooth, quiet travel

Key Facts

Typical Use

Skylights, Blackout

Shape

Rectangular

Running Direction

Any

Guides

Aluminium profile

Width

650 mm - 3000 mm

Draw

≤3000mm / ≤4500mm

Fabric Area

≤9 m²/≤13m²

Brackets

Aluminium

Finish

RAL Powder Coat

Installation Options

Face/Reveal



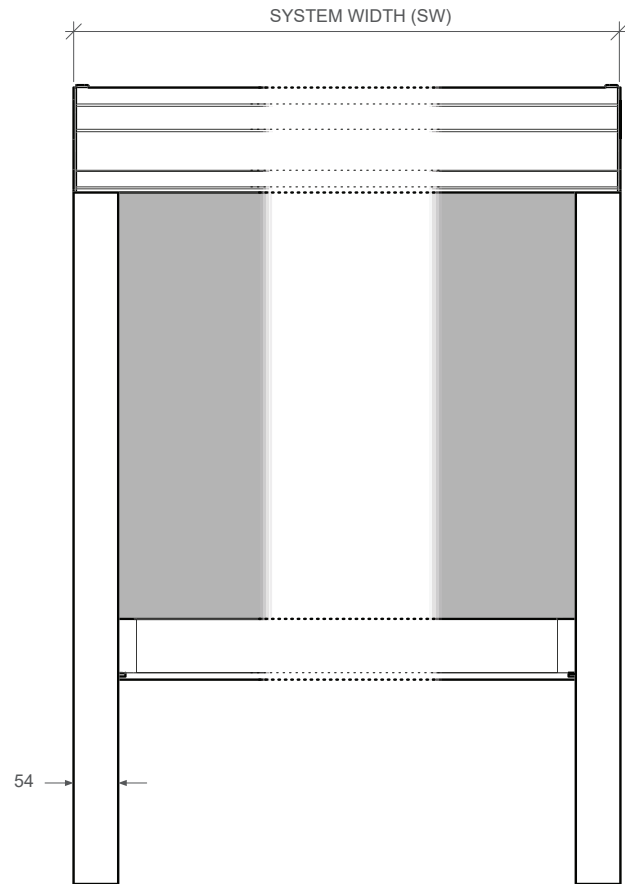
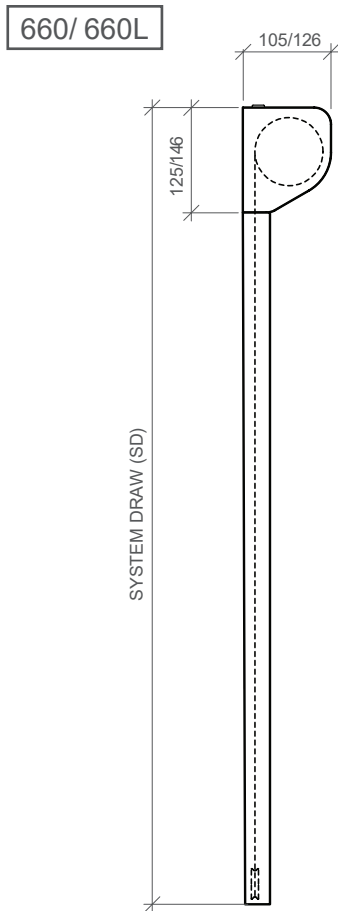

Technical Information

Fabric Tension

>100N

Weight exc. fabric

~8 kg + 4 kg/m width + 1.6 kg/m draw

Fixing load

≤5 kg per fixing point

Operating temp.

0 to 55 °C

Motor

9 Nm, 12 rpm

Max run time

4 min

Fabric Speed

~3 m/min

Control

Radio/Wired

Electrical

230 V, 50 Hz, 120 W, 0.55A

120 V, 60 Hz, 130 W, 0.98A

